

L-326

# RENA HEAVY-DUTY LABELER/TABBER



*All-in-one design provides the easiest, most efficient way to label and tab your outgoing mail.*

- Fast — labels or tabs up to 22,500 mailing pieces per hour.

- Handles a wide variety of mail sizes — up to 5/16" thick.

Visit Us  
[www.RenaUSA.com](http://www.RenaUSA.com)  
On The Web

# RENA L-326

# RENA HEAVY-DUTY LABELER/TABBER

**Label it. Tab it. Profit from the flexibility of the RENA L-326.**

The L-326 combines RENA's superior labeling and tabbing technology to make your mail center more efficient and profitable. It offers all the advantages and cost savings of high-speed labeling and tabbing in one compact unit.

**Fastest labeler in its class.** When you need to get the mail out fast, you need a RENA L-326. It applies pressure-sensitive labels at speeds up to 22,500 mailing pieces per hour. The L-326 applies standard address labels, as well as transparent labels, to give your mail a more professional look.

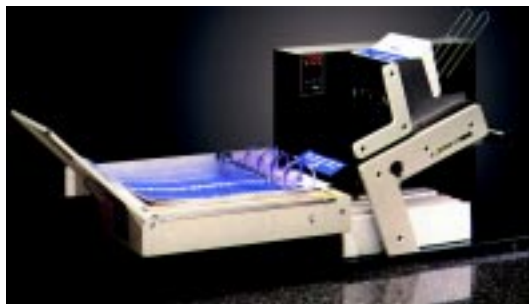

*The RENA L-326 Heavy-duty Labeler/Tabber with Optional Conveyor/Stacker*

**Helps you comply with USPS automation discount requirements.** If you're mailing open-ended pieces, it takes more than a postal barcode to qualify for USPS automation discounts. You'll also have to tab/seal the open end of each mailing piece. That's where the L-326 saves you even more. It tabs at speeds of up to 22,500 pieces per hour. And, it even applies transparent tabs that won't interfere with the design of the mailing piece.

**Easy to operate.** With its convenient control panel you can easily adjust labeling/tapping speed and label placement, and choose from a variety of programming options.

**Easy to afford.** The L-326 is the most affordable table-top, production labeler/tabber available. And with its highly efficient operating speeds, it can easily pay for itself within a few months.

## Designed to make labeling and tabbing easier!

Easy-to-use control panel, with on-screen display, lets you quickly adjust labeling speed, label placement, and programming options.

Microprocessor control lets you make fast, easy adjustments for different label and tab stock.

Unique reflective sensor enables you to apply clear address labels and tabs to give your mailings a more professional look.

Feeding system lets you label stuffed envelopes, catalogs, magazines, and mailing materials up to 5/16" thick.

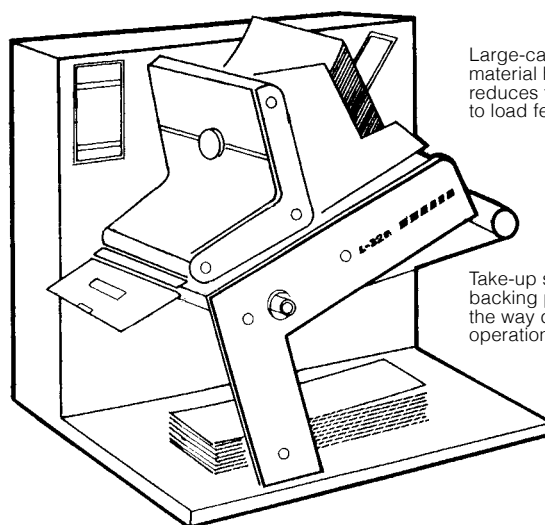

Large-capacity material hopper reduces time needed to load feeder.

Take-up spool keeps backing paper out of the way during operation.

### Mediatec, Inc.

1 Goundry Drive  
Waterford, CT 06385  
(860) 442-9986, Fax: (860) 442-6230  
Email: [bmayo@mediatecinc.com](mailto:bmayo@mediatecinc.com)

### Replication Technology, Inc.

1110 4th Avenue  
Napa, CA 94559  
(707) 255-8800, Fax: (707) 255-8889  
Email: [brubin@replicationtechnology.com](mailto:brubin@replicationtechnology.com)

## L-326

## Specifications

<b>Speed:</b>	Up to 22,500 pieces per hour
<b>Material Size:</b>	2-3/4" to 31-1/2" long 3-1/8" to 15-1/2" wide Up to 5/16" thick
<b>Label Size:</b> (Continuous one-up paper labels)	3/4" to 6-1/4" long
<b>Tab Size:</b> (Continuous one-up paper tabs)	1-1/8" to 7" wide 3/4" to 1-3/8" long 3/4" to 1-7/8" wide

<b>Counter:</b>	5-digit digital display; continuous count shows total number of labels/tabs applied over life of machine
<b>Feeder:</b>	Features continuous feed and automatic shut-off when the feeder is empty
<b>Dimensions:</b>	20-3/4"L x 19"H x 13-1/2"W
<b>Weight:</b>	60 lbs.
<b>Electrical Req.:</b>	110 Volts: 60 Hz
<b>Options:</b>	RENA Conveyor Stacker